

# NL4-PP INSTALLATION and OPERATION GUIDE

→→→ FOR THOSE BOATS WITH Perfect Pass™ using Paddle Wheels ←←←

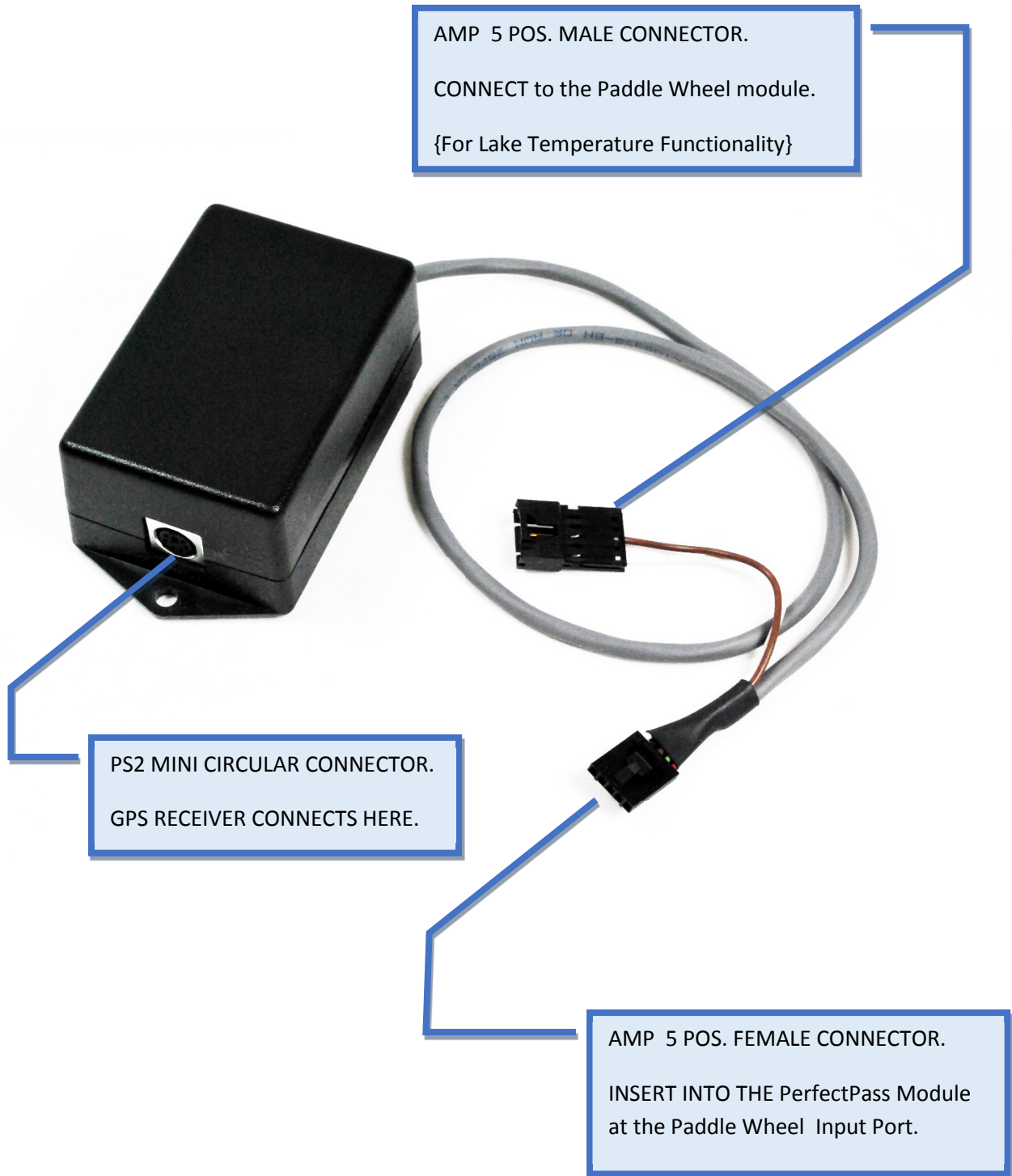

## NL4-PP INSTALLATION and OPERATION GUIDE

The installation of the NL4 is simple. This is a retro-fit. The NL4's power and signal connector is identical to your existing paddle-wheel connector. Your tasks are basic: locate the GPS pod, mount the NL4, unplug the paddle-wheel, and attach the NL4. Wire stripping and/or splicing are NOT required.

### TURN OFF THE POWER and DISCONNECT THE BATTERY.

#### Locate the GPS Receiver.

The NL4 compatible GPS Receiver is waterproof with great reception. It's resilient and tolerant in marine surroundings. These following constraints are key: the GPS requires a clear line-of-sight to the sky; the windshield and/or cloth top shouldn't present a problem. Keep it away from other electronics / antenna's that may interfere with the receiver. Every boat is different, so experiment with varied Receiver locations to find the best (before mounting it permanently). Route the GPS cable / connector to the PerfectPass Module.

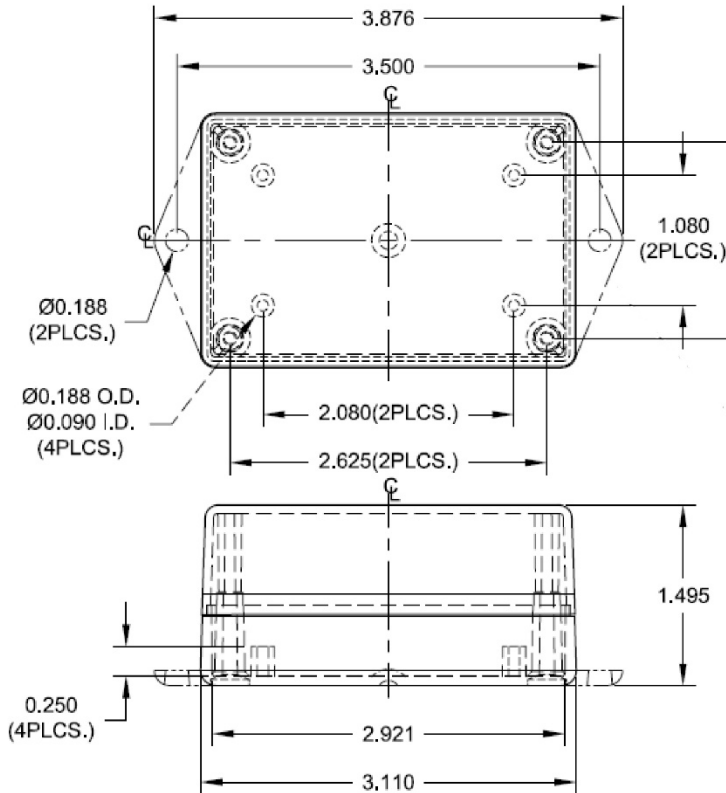

#### NL4 Mounting Considerations.

The case provides two mounting flanges with #8 screw holes. Use these to secure the NL4 to a flat surface adjacent to the PerfectPass Module. (The #8 screws are not provided.)

#### Attach the NL4.

Remove the paddle-wheel connector from the PerfectPass Module: *Paddle Input* is clearly marked on the Module's Face or Harness. In its place, insert the NL4's five-position Female connector back into PerfectPass Module. Make sure the mating connector latches engage.

#### \*\* Preserve Lake Temperature Option.

Insert the free paddle-wheel connector into the NL4's five-position male connector. This will reconnect the paddle-wheel's temperature sensor with the PerfectPass Module. Make sure the mating connector latches engage.

## NL4-PP INSTALLATION and OPERATION GUIDE

### **Attach GPS Receiver.**

Plug the GPS Receiver into the NL4's PS2 connector. Note the 'ARROW' embossed into the connector. Orient the arrow at 12 o'clock, or away from the mounting flange. Be sure to strain relief the GPS Receiver cable/connector, with a cable tie to a nearby fixed provision.

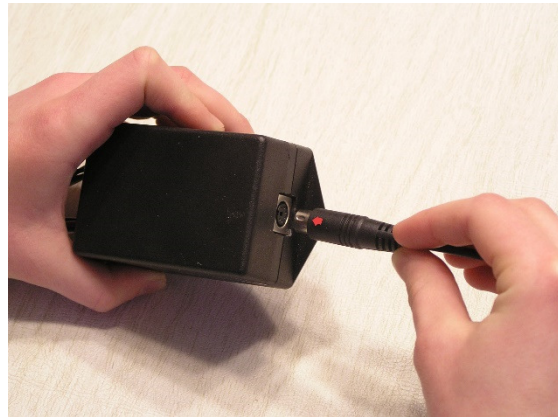

Re-connect the Battery.

### **Operation.**

The NL4's sole function is to communicate speed data from the GPS Receiver to the PerfectPass Module. The NL4 will in NO-WAY interfere or meddle with normal PerfectPass functions. The format of the NL4's speed output is an exact match to the paddle-wheels, and is a seamless integration into the speed control system.

On a 'cold start' (power turned on after a prolonged off period) the GPS Receiver will require 1 - 2 minutes to sync to the satellites. With a warm start, expect the satellite sync within seconds.

The GPS Receiver is equipped with an internal Status Light.

1. THE LIGHT FLASHES: When the Receiver has power.
2. THE LIGHT REMAINS SOLID: When the Receiver has a Satellite Sync. This is required for normal operation.

### **Settings and Calibration.**

A Speed Calibration is required! Follow instructions outlined in the PerfectPass Instruction Manual. Typically, the Paddle-wheel's speed will register 1 to 2 mph slower than the faster NL4. A handheld GPS is an excellent speed reference.

For crisper speed control, significantly reduce the 'NN' Paddle-Wheel Filter. The NL4's output signal is ultra-clean and this filter is not needed: Should you decide to change the NN filter, do it in incremental steps. For example: drop the value by 20%. Run the boat for 1 hr. If there was an improvement or none, then drop it by another 20%. Run it for an hour. Repeat. If the response ever degrades, then bump the value back up 10%.

**Warranty.** Nautic Laugic warranties the NL4 for one year.

Should this product malfunction or fail, please return it so we can make it right!! Please see our policies page at [www.nauticlaugic.com](http://www.nauticlaugic.com)

THANK YOU FOR BUYING OUR PRODUCT!!

