

NL4-SD INSTALLATION and OPERATION GUIDE

→→→ FOR THOSE BOATS WITH *Triducer Multisensor 20-459-01* Paddle Wheels ←←←



NL4-SD INSTALLATION and OPERATION GUIDE

The installation of the NL4 is simple. This product is a retro-fit. The NL4's 'power and signal' connector is identical to your existing paddle-wheel connector. Your tasks are basic: locate the GPS pod, mount the NL4, unplug the paddle-wheel, and attach the NL4. Wire stripping and/or splicing are NOT required.

TURN OFF THE POWER and DISCONNECT THE BATTERY.

Locate the GPS Receiver.

The NL4's compatible GPS Receiver is weatherproof with great reception. It's resilient and tolerant to marine surroundings. These following constraints are key: the GPS requires a clear line-of-sight to the sky; the windshield and/or cloth top shouldn't present a problem. Keep it away from other electronics / antenna's that may interfere with the receiver. Every boat is different, so experiment with varied Receiver locations to find the best one (before mounting it permanently).



Find the paddle-wheel connectors. They will appear like the two Deutsch connectors (see first page) mated together. The usual location is near the paddle-wheel. Route the GPS cable towards the paddle-wheel connector.

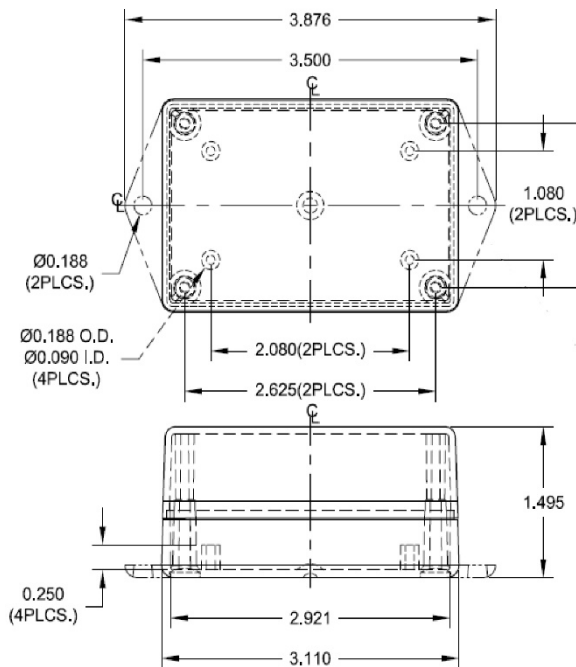

latches engage.

NL4 Mounting Considerations.

Pick a protected area like under the dash, or high in a gunwale. The NL4 is not water-proof. The NL4 provides two mounting flanges on its case. Use these to secure the case on a flat surface, that's in reach of both the GPS Receiver and paddle-wheel connectors. The mounting holes accept #8 screws (not provided).

Attach the NL4.

Thread the NL4's Grey cable/connectors to the paddle-wheel connector. Separate the mating halves of the computer-to-paddle-wheel connector. Insert the NL4's eight-position male connector into the computer's eight-position female; Make sure the mating connector latches engage.

To preserve the Depth Sounder and Lake Temperature functions from the paddle-wheel, insert the free paddle-wheel plug into the NL4's eight-position socket (female) connector. Make sure the connector

NL4-SD INSTALLATION and OPERATION GUIDE

Attach GPS Receiver.

Plug the GPS Receiver into the NL4's PS2 connector. Note the 'ARROW' embossed into the connector. Orient the arrow at 12 o'clock, or away from the mounting flange. Fully insert the metal shell/pins into the socket. Be sure to strain relief the GPS Receiver cable/connector, with a cable tie to a nearby fixed provision.

Reconnect the Battery.

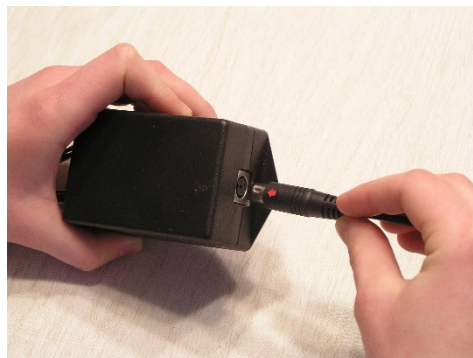

Operation.

The NL4's sole function is to communicate speed data from the GPS Receiver to the Instrumentation (Dash) Computer Module. The NL4 will in NO-WAY interfere or meddle with normal computer functions. The format of the NL4's speed output is an exact match to the paddle-wheels, and is a seamless integration into the computer system.

On a 'cold start' (power turned on after a prolonged off period) the GPS Receiver will require 1 - 2 minutes to sync to the satellites. With a warm start, expect the satellite sync seconds.

The GPS Receiver is equipped with an internal Status Light.

1. THE LIGHT FLASHES: When the Receiver has power.
2. THE LIGHT REMAINS SOLID: When the Receiver has a Satellite Sync. This is required for normal operation.

Calibration.

Follow the Speedometer Calibration instructions outlined in the Boat Manufacturer's Instruction Manual. Typically, the Paddle-wheel's speed will register 1 to 2 mph slower than the cleaner, faster NL4. A handheld GPS is a good speed reference.

PerfectPass Equipped: Follow the Calibration instructions outlined in the PerfectPass Instruction Manual. For crisper speed control, significantly reduce the 'NN' Paddle-Wheel Filter. The NL4's output signal is ultra-clean and this filter is unnecessary; see the PerfectPass manual for instruction.

Guarantee. We want Satisfied Customers! Satisfaction within the first 30 Days, or return it for a refund.

Warranty. Nautic Laugic warranties the NL4 for one year. Should this product malfunction or fail, please return it so we can make it right!! Please see our policies page at www.nauticlaugic.com

THANK YOU FOR BUYING OUR PRODUCT!!

